

DESIGNED
ARCHITECTURAL
LIGHTING

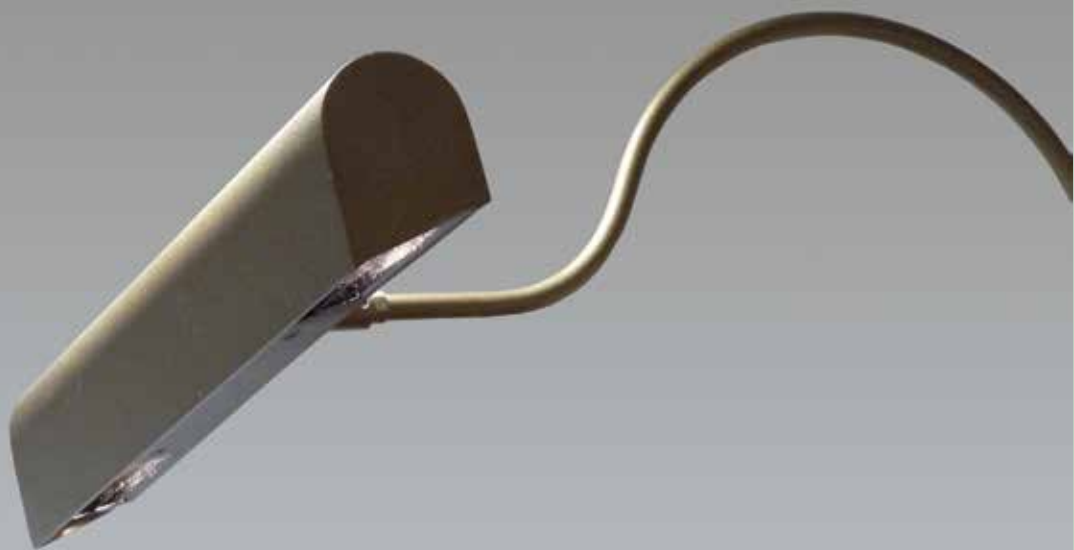

Pro-Art[®]
PICTURE LIGHT



Pro-Art[®]

PICTURE LIGHT

Lighting a painting can be achieved in a number of ways, most successfully from above the picture, either by accent lighting from spotlights, recessed directional downlights or framing projectors. Another flexible solution is to light the picture from a local 'picture light', either mounted on the rear of the picture frame or on the wall.

Traditionally the light source within picture lights was, formerly a linear incandescent tungsten lamp, and latterly more efficient low voltage tungsten halogen lamps. These light sources, whilst offering good solutions within the parameters of technology at the time, are relatively inefficient and emit damaging ultra-violet and infrared radiation.

Today with the evolution of solid state technology and progressive product design an LED light source can be utilised to provide stable white light with excellent colour appearance and rendition offering long life, and minimal energy consumption. The DAL Pro-Art[®] picture light series has been specially developed to achieve this, providing superb quality and controlled light within an elegant practical format.



Pro-Art[®] Picture Light

A high quality extruded aluminium housing with seamless ends mounted from either one or two 'swan neck' support arms, with adjustable and lockable 'knuckle joints'.

The picture lights are manufactured in dedicated lengths to light a wide variety of painting sizes and are finished with a specially formulated 'old gold' matt polyurethane enamel with excellent colour durability and chemical resistance. Alternative colour finishes and wall arms can be offered to change the appearance if a contemporary aesthetic is desired. For larger width artwork a combination of picture lights will solve the problem.

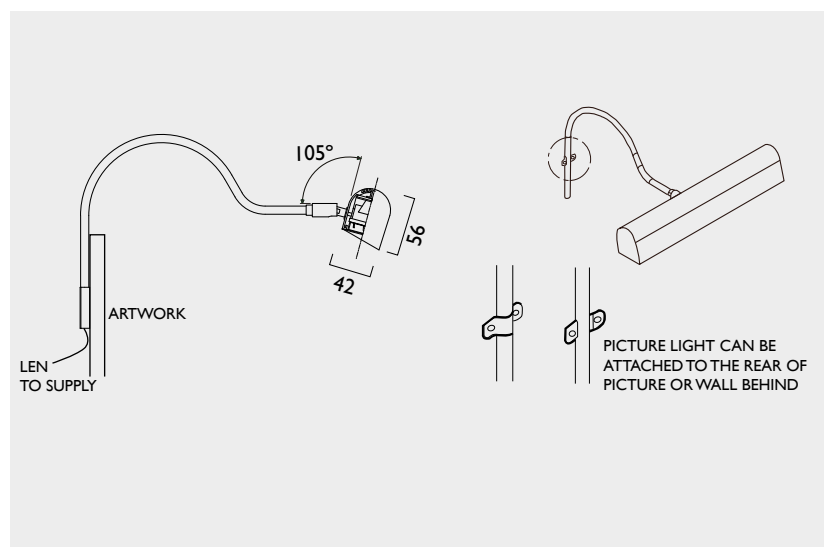

Light Source: High quality LED's
 Colour Rendering: Excellent CRI 97
 Colour Temperature: Warm 2700°K, 3000°K or 4000°K available for cooler colour appearance if desired.
 Longevity: 50,000 hrs L80
 Light Control: Even dimming to 5% is achieved by a rotary control mounted on the end of housing. This operates an integrally mounted driver. Alternative drivers are available to suit remote lighting control systems.

Optical Performance: Internal reflectors and lens system control the light distribution resulting in a more even appearance.
 Glare: A louvre within the fascia reduces distracting glare.
 Energy (LED initial): >100 lms/w, see chart below
 Construction: IP20 (dry interior use)
 Mounting: Saddle brackets are provided to locate the arms to the picture frame or wall.
 Electrical Supply: 230v 50Hz. A plug and socket is provided for the electrical connection.
 Manufacture: Made in the UK.

The chart below indicates typical width of pictures (without frame) and the size of the picture lights required.

Whilst the optical system within the picture light projects light down the picture, it must be accepted that pictures will not be evenly lit. The chart is an indication, and will depend on the artwork being lit.

Pro-Art® Picture Light Matrix:				
Part No:	Model	TYP (W)	Product Width (mm)	Typical width of painting (mm)
H0902	2-Lights	10.8	296	300-670
H0903	3-Lights	16.2	520	670-800
H0904	4-Lights	21.6	744	800-970
H0905	5-Lights	27	968	970-1200
H0906	6-Lights	32.4	1192	1200-1450

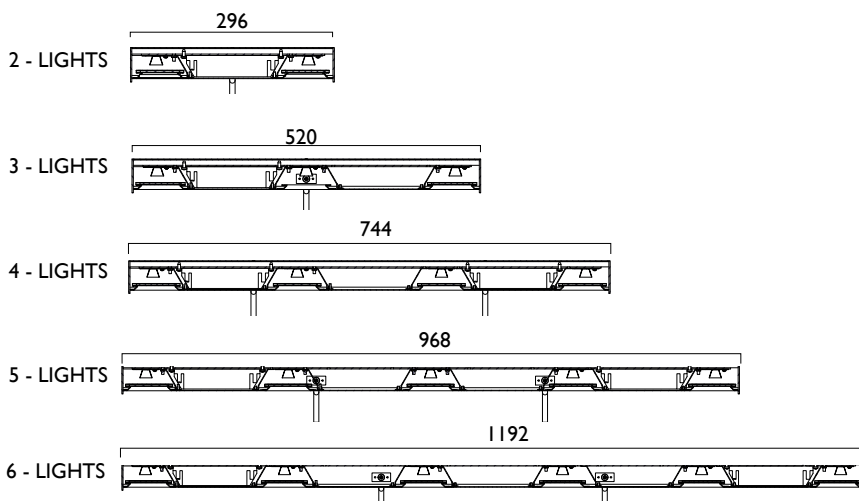

Even Distribution.

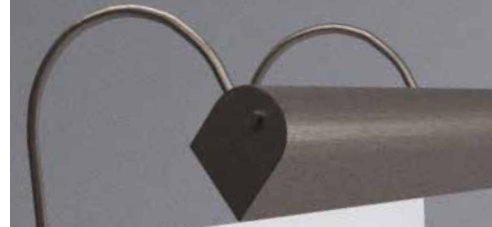

Integral Dimmer.

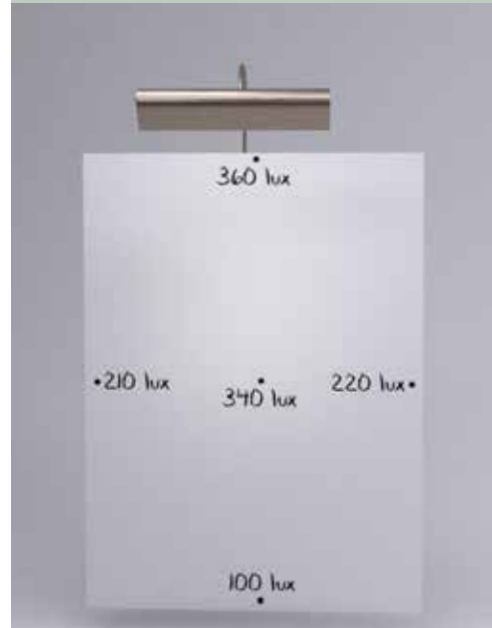

Indicative at full output. Typical size of painting 750mm width x 1040mm height.



[www.twitter.com
@DAL_Ltd](https://www.twitter.com/DAL_Ltd)



[www.facebook.com
Designed Architectural Lighting Ltd](https://www.facebook.com/DesignedArchitecturalLightingLtd)



www.dal-uk.com



sales@dal-uk.com